

Grandglow® GRANDGLOW NEW ENERGY TECHNOLOGY CO.,LTD.

Add: No. 278, Zhongshan Avenue, Huangjinshan Development Zone, Huangshi, China Zip: 435000
 Tel: +86-714-6366111 Fax: +86-714-6368000 Email: sales7@grandsolar.cn M.P.: (wechat) +86-18995802555 Attn: Jason Zhang

MODEL: GRANDGLOW TLC6000 1D



- Can be applied to various fields, mainly for solar power, wind power, battery power, and scenery lamp power
- Advanced MPPT tracking technology, Wide MPPT voltage range.
- Strong IP65 protection, completed sealed cover suitable for harsh environment.
- No isolation transformer H6 full-bridge configuration, highest efficiency reach 98 %.
- Over voltage, short circuit, overload, overheating, Anti-islanding protection etc.
- Multiple Inverters can be operated in Parallel.
- LCD display, convenient for user to monitor main parameters.
- Support various Communication modes.
- 5-year warranty period, can be extended 10 year warranty.

DC Input	
Maximum DC Input Power	6600W
Maximum DC Input Voltage	850VDC
Maximum DC Input Current	20A
MPPT Tracking Number/ Input String Number	1
MPPT Tracking Voltage Range	200-820VDC
Power Off/On Voltage	200/300VDC

Grandglow® GRANDGLOW NEW ENERGY TECHNOLOGY CO.,LTD.

Add: No. 278, Zhongshan Avenue, Huangjinshan Development Zone, Huangshi, China Zip: 435000

Tel: +86-714-6366111 Fax: +86-714-6368000 Email: sales7@grandsolar.cn M.P.: (wechat) +86-18995802555Attn: Jason Zhang

AC Output	
Rated Power	6000W
Voltage Range	AC 400V(360-440V) Adjustable according to different countries and regions requirement.
Rated Voltage Range	400VAC
Frequency	50Hz
Phase number	Three Phase
Power Factor	0.99
Max Output Current	9 A
Current THD	At Rated Power And In The Sine Wave <3.5%
Max Efficiency	98%
Europe Efficiency	97%
MPPT Efficiency	99.5%
Structure	
Protection Degree	IP65
Cooling Method	Intelligent air cooling
Noise	<50dB
Data Interfaces	RS 485/ RS 232/ (Standard), WiFiModular(Optional)
Isolation type	Non-isolated
Standby Power Consumption	0W
LCD Display	LCD
DC Switch	Integration

Grandglow® GRANDGLOW NEW ENERGY TECHNOLOGY CO.,LTD.

Add: No. 278, Zhongshan Avenue, Huangjinshan Development Zone, Huangshi, China Zip: 435000

Tel: +86-714-6366111 Fax: +86-714-6368000 Email: sales7@grandsolar.cn M.P.: (wechat) +86-18995802555 Attn: Jason Zhang

Protection	
Support	DC Input Switch, Anti-island, Output Over-current, Input Reverse Connection, DC/AC Surge Protection, Insulation Resistance Testing, RCD Testing, Upgrade WIFI
RCD Testing	Support
Protection (Inverter)	Input Overvoltage, Output Short Circuit, Overload, Overheat
Protection (Grid)	Anti-islanding(IEEE1547), over/under voltage of grid, over/under frequency of grid.
General Parameters	
Input Terminal	MC4
Output Terminal	Connect Terminals
Topology	No Transformer
Warranty	5 Years Warranty, Can Be Extended to 10 years
State Grid Function	Yes
AC Switch	Integration
Operation temperature Range	Air Flow, -20 °C ~50 °C
Storage temperature	-25 °C ~ 60 °C
Relative humidity	0~95%
Environment	No Corrosion Gas, Flammable Gas, Gas Fumes and Dust Etc
Altitude	6600 Feet 2000m, Max. 3000m
Size	440x560x260mm
Weight	38kgs
* OEM available, ODM available.	

Grandglow[®] GRANDGLOW NEW ENERGY TECHNOLOGY CO.,LTD.

Add: No. 278, Zhongshan Avenue, Huangjinshan Development Zone, Huangshi, China Zip: 435000

Tel: +86-714-6366111 Fax: +86-714-6368000 Email: sales7@grandsolar.cn M.P.: (wechat) +86-18995802555 Attn: Jason Zhang

Efficiency Curve: GrandGlowTLC8000-15000

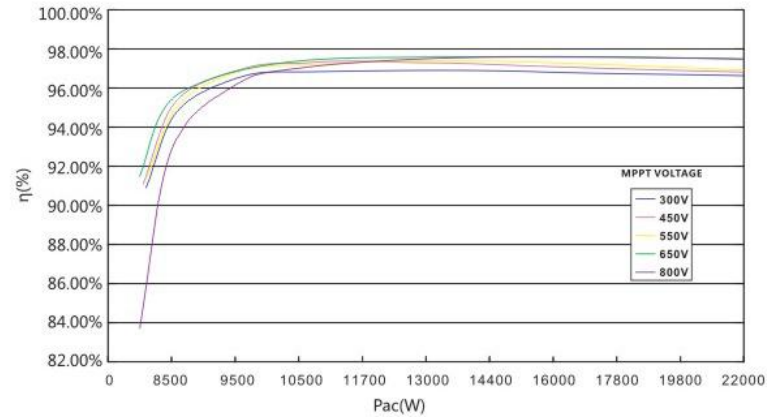

The Topology Diagram: GrandGlowTLC3000-15000

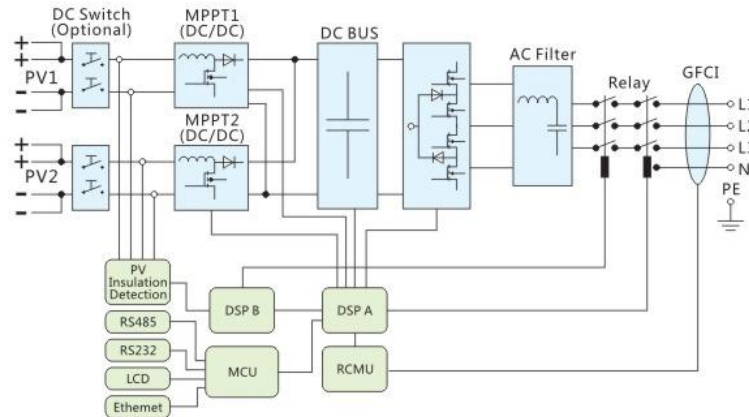

Grandglow[®] GRANDGLOW NEW ENERGY TECHNOLOGY CO.,LTD.

Add: No. 278, Zhongshan Avenue, Huangjinshan Development Zone, Huangshi, China Zip: 435000

Tel: +86-714-6366111 Fax: +86-714-6368000 Email: sales7@grandsolar.cn M.P.: (wechat) +86-18995802555 Attn: Jason Zhang

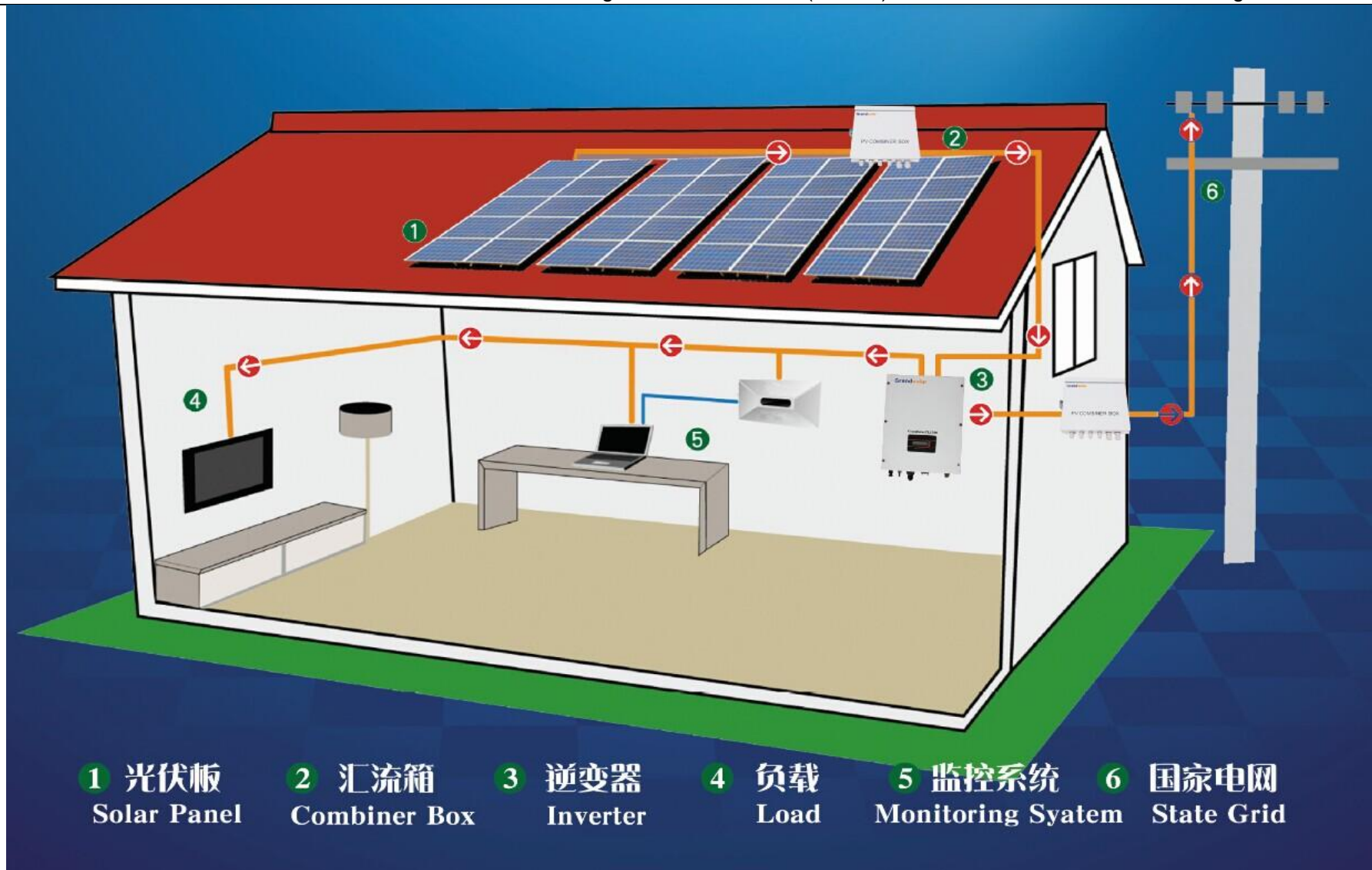

Grandglow® GRANDGLOW NEW ENERGY TECHNOLOGY CO.,LTD.

Add: No. 278, Zhongshan Avenue, Huangjinshan Development Zone, Huangshi, China Zip: 435000

Tel: +86-714-6366111 Fax: +86-714-6368000 Email: sales7@grandsolar.cn M.P.: (wechat) +86-18995802555 Attn: Jason Zhang

Grandglow®



About Grandglow

Grandglow New Energy Technology Co., Ltd. is specialized in the field of R&D, manufacture and market of the New Energy Electrical & Electronic Products, including:

- Grid Tie Solar Inverter
- Off Grid Solar Inverter
- Solar Pump Inverter
- PV combiner box
- Solar Charge Controller
- Solar Power System Design and Install.

Company Area: 66000m², 4 workshops.

Quality Certification: CE, TUV, VDE, SAA, IEC, G83, En62019, etc.

Brand Concept:

- Higher Quality
- Higher Service
- Better Cost Performance.

Company Pursuit:

- Innovation
- Excellence
- Outstanding